



BAV99

SOT-23 Dual Series Switching Diode
SOT-23 双串开关二极管

1. Description 描述

High-voltage switching diode encapsulated in a small SOT-23 Surface-Mounted Device (SMD) plastic package.

这种高压开关二极管采用小型 SOT-23 表面贴装 (SMD) 塑料封装。

2. Features 特性

Feature 特性	Description 描述
Reverse Voltage 反向电压	$V_R = 75V$
Forward Work Current 正向工作电流	$I_F = 200mA$
Applications 应用	<ul style="list-style-type: none">Extremely fast switching speed 高速开关For general-purpose switching applications 通用开关应用场景High conductance 高电导
Environmental Compliance 环保合规	Totally Lead-Free & Fully RoHS Compliant. 完全无铅和符合 RoHS 标准 ^[1] Halogen and Antimony Free, "Green" Device. 无卤素和无锑, "绿色"器件 ^[2]
Automotive Compliance 汽车合规	Qualified according to AEC-Q101 and recommended for use in automotive applications. 通过了 AEC-Q101 认证, 推荐用于汽车电子应用场景。

[1] No purposely added lead. Fully EU Directive 2002/95/EC (RoHS), 2011/65/EU (RoHS 2) & 2015/863/EU (RoHS 3) compliant.

无铅, 完全符合欧盟标准 2002/95/EC (RoHS), 2011/65/EU (RoHS 2) 和 2015/863/EU (RoHS 3)。

[2] Halogen- and Antimony-free "Green" products are defined as those which contain <900ppm bromine, <900ppm chlorine (<1500ppm total Br + Cl) and <1000ppm antimony compounds.

无卤素和无锑的“绿色”产品指溴含量<900ppm, 氯含量<900ppm (溴+氯总含量<1500ppm) 和锑化合物含量<1000ppm。

3. Mechanical Data 封装数据

Feature 特性	Description 描述
Package 封装	SOT-23
Moisture Sensitivity Level 湿敏感度等级	J-STD-020 MSL1
Material 材料	Molded Plastic, "Green" Molding Compound; UL Flammability Classification Rating 94V-0. 模塑塑料封装, "绿色" 成型复合材料; UL 可燃性等级 94V-0.
Dimensions 尺寸	1.9mm pitch; 2.9mm × 1.3mm × 1.0mm body 相邻引脚中心距为 1.9mm, 封装本体 (不含引脚) 尺寸为 2.9mm × 1.3mm × 1.0mm
Terminals Compliance 引脚合规	3 terminals, Tin Plated Leads, Solderable per MILSTD-202, Method 208 ^③ 3 个镀锡引脚, 可焊性符合 MIL-STD-202 标准中 208 方法 e3 条款的要求
Weight 重量	0.008 grams (Approximate) 约 0.008 克
Polarity 极性	See Diagrams Below 极性见下图

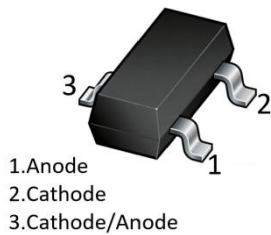

SOT-23 Top View

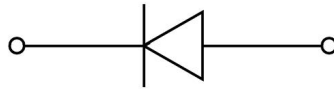

Device Symbol

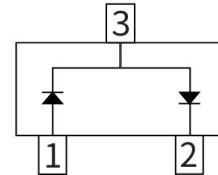

Top View Pin-Out

4. Ordering Information 订购信息

Part Number	Compliance	Package	Reel Size (inches)	Tape Width (mm)	Quantity Per Reel
BAV99	Automotive	SOT-23	7	8	3000

5. Marking Information 丝印信息

Part Number	Marking Code
BAV99	A7



6. Absolute Maximum Ratings($T_a = +25^\circ\text{C}$) 绝对最大额定值

Characteristic 特性	Symbol 符号	Value 值	Unit 单位
Repetitive Peak Reverse Voltage 重复峰值反向电压	V_{RRM}	100	V
Reverse Work Voltage 反向工作电压	V_{RWM}	100	V
DC Reverse Voltage 直流反向电压	V_R	75	V
Forward Work Current 正向工作电流	$I_F(I_O)$	200	mA
Non-Repetitive Peak Forward Current 非重复性正向峰值电流	I_{FSM}	$t_p = 1\mu s$ 2	A
		$t_p = 1ms$ 1	
		$t_p = 1s$ 0.5	

7. Thermal Characteristics($T_a = +25^\circ\text{C}$) 热特性

Characteristic 特性	Symbol 符号	Value 值	Unit 单位
Power Dissipation 耗散功率	P_D	225	mW
Thermal Resistance From Junction To Ambient 结到环境的热阻	$R_{\theta JA}$	555	$^\circ\text{C}/\text{W}$
Junction Temperature 结温	T_J	-55 ~ +150	$^\circ\text{C}$
Storage Temperature 储藏温度	T_{stg}	-55 ~ +150	$^\circ\text{C}$

**8. Electrical Characteristics($T_a = + 25^\circ\text{C}$) 电特性**

Characteristic 特性	Symbol 符号	Min. 最小值	Typ. 典型值	Max. 最大值	Unit 单位	Conditions 条件
Reverse Breakdown Voltage 反向击穿电压	$V_{(BR)}$	100	-	-	V	$I_R = 100\mu A$
Reverse Leakage Current 反向漏电流	I_R	-	-	2.5	μA	$V_R = 75V$
Forward Voltage 正向电压	V_F	-	-	0.715	V	$I_F = 1mA$
		-	-	0.855	V	$I_F = 10mA$
		-	-	1	V	$I_F = 50mA$
		-	-	1.25	V	$I_F = 150mA$
Diode Capacitance 二极管电容	C_D	-	-	1.5	pF	$V_R = 0, f = 1MHz$
Reverse Recovery Time 反向恢复时间	t_{rr}	-	-	6	ns	-



9. Typical Electrical Characteristics Curve 典型电特性曲线

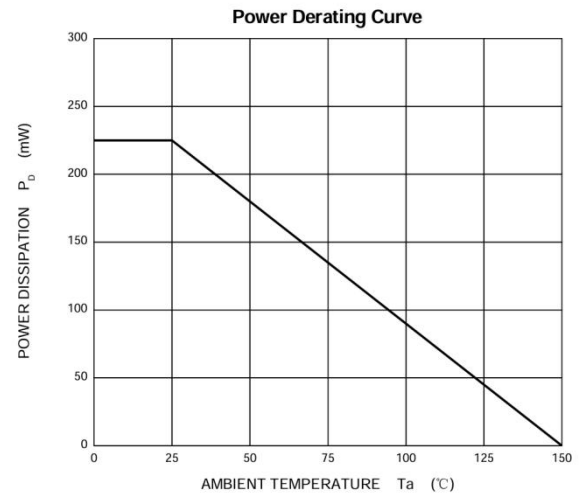
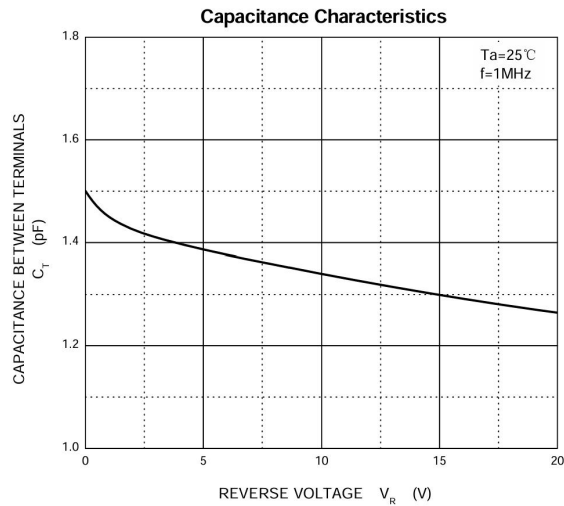
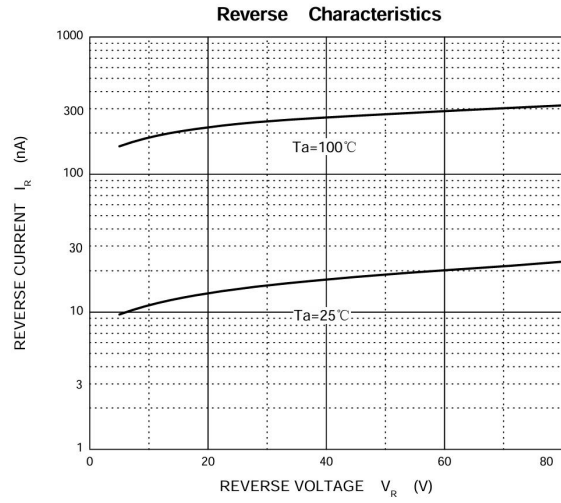
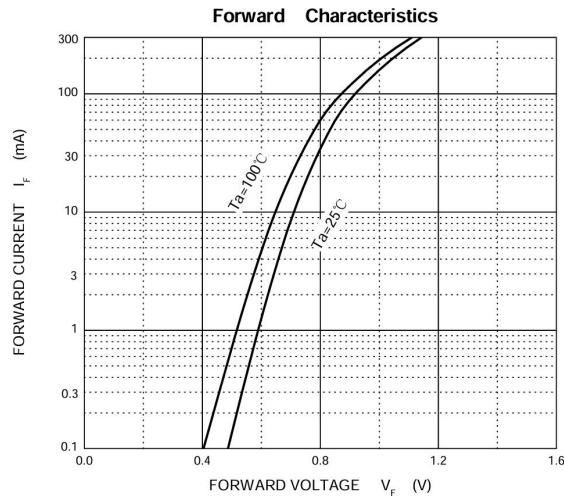

10. Package Outline Dimensions 封装外形尺寸

SOT-23

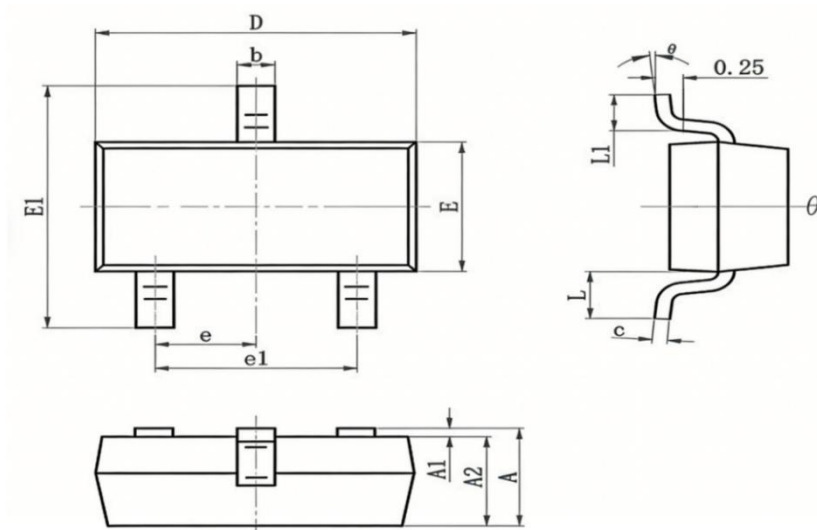

Symbol 符号	Millimeters 毫米	
	Min.最小值	Max.最大值
A	0.900	1.150
A1	0	0.100
A2	0.900	1.050
b	0.300	0.500
c	0.080	0.150
D	2.800	3.000
E	1.200	1.400
E1	2.250	2.550
e	0.900	1.000
e1	1.800	2.000
L	0.500	0.600
L1	0.300	0.500
θ	0°	8°

11. Suggested Pad Layout 推荐焊盘布局

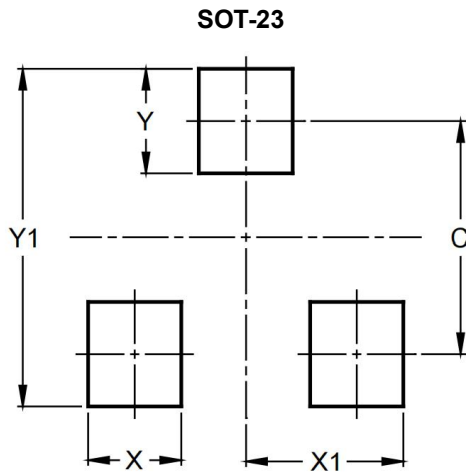

Dimensions 尺寸	Millimeters 毫米
C	2.0
X	0.8
X1	1.35
Y	0.9
Y1	2.9

Fig. Soldering footprint for SOT-23

图 SOT-23 的引脚焊接



Important Notice 重要通知

Jingpeng Hulian('JPHL') company make no warranty of any kind,express or implied,with regards to any information contained in this document.Including,but not limited to, the implied warranties of the accuracy, completeness, merchantability, or non-infringement of third party intellectual property rights.

京鹏沪连公司(以下简称“JPHL”)对本文件包含的所有信息不提供任何明示或默认的担保,包括但不限于关于信息的准确性、完整性、适销性,以及不侵犯第三方知识产权的默认保证。

The Information contained herein is for informational purpose only and is provided only to illustrate the operation of JPHL products described herein and application examples. JPHL does not assume any liability arising out of the application or use of this document or any product described herein.

本文件内容仅作信息参考,仅用于说明文中所述 JPHL 产品的操作方法及应用示例。JPHL 不承担因应用或使用本文件或本文件中描述的任何产品而产生的任何责任。

JPHL reserves the right to make changes to information published in this document, at any time and without notice. This document supersedes and replaces all information supplied prior to the publication hereof.

JPHL 保留随时修改本文件已发布信息权利,且不另行通知,本文件将取代并替换其发布前提供的所有相关信息。

All referenced brands, product names, service names and trademarks are the property of their respective owners.

本文提及的所有品牌、产品名称、服务名称和商标,均归属其各自所有者。



Contents 目录

1. Description 描述.....	1
2. Features 特性.....	1
3. Mechanical Data 封装数据.....	2
4. Ordering Information 订购信息.....	2
5. Marking Information 丝印信息.....	2
6. Absolute Maximum Ratings($T_a = + 25^\circ\text{C}$) 绝对最大额定值.....	3
7. Thermal Characteristics($T_a = + 25^\circ\text{C}$) 热特性.....	3
8. Electrical Characteristics($T_a = + 25^\circ\text{C}$) 电特性.....	4
9. Typical Electrical Characteristics Curve 典型电特性曲线.....	5
10. Package Outline Dimensions 封装外形尺寸.....	6
11. Suggested Pad Layout 推荐焊盘布局.....	7
Important Notice 重要通知.....	8

© JPHL. 2025. All rights reserved

For more information, please visit: www.jphl-semi.com

For business cooperation, please send an email to: sales@jphl-semi.com

Date of release: 26 Dec 2025

©京鹏沪连. 2025. 版权所有

想了解更多信息, 请访问 www.jphl-semi.com

商务合作请发送电子邮件至 sales@jphl-semi.com

发布日期: 2025-12-26
